

# CS SERIES

## LOW-COST LENGTH SENSOR



Simple structure with reed switch installed.  
 Good for measuring the length of paper, cloth, film, etc.  
 by combining with an electronic counter or an electromagnetic counter.

### MODEL

Model	Sensor	Unit	Speed	Weight	Rotation Torque	Proper Counter	
CS-3:1	Reed Switch	1m[yard]	500meter [yard]/minute	740g [26oz.]	15mN·m	Electronic Counter / Electromagnetic Counter	
Operating Temperature		-5 - +40°C [14 - 122°F] (Non-freezing)			Operating Humidity		85% max. (Non-Condensing)

### CONNECTION

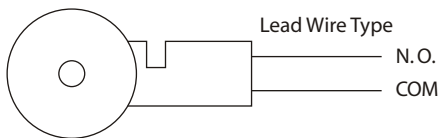

Current Rating : 50VA (maximum)  
 Maximum Current : 2.5A  
 Maximum Voltage (ON/OFF) : 350VDC / 300VAC  
 Maximum current (ON/OFF) : 0.5A  
 Make : 1:1 ( ON 1.5 rotation, OFF 1.5 rotation )

### NOTE

1. For the connection with an electronic counter, use a contact - input terminal.
2. It is recommendable to use such components as diode, CR etc., for the protection of contact in the case of connection with such inductive load as electromagnetic counter.

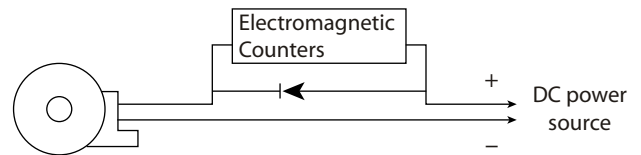
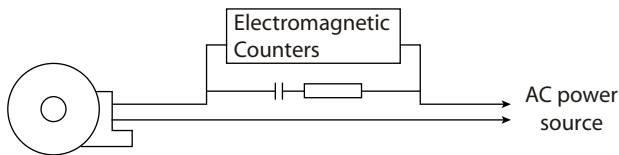

### DIMENSIONS(Unit : mm)

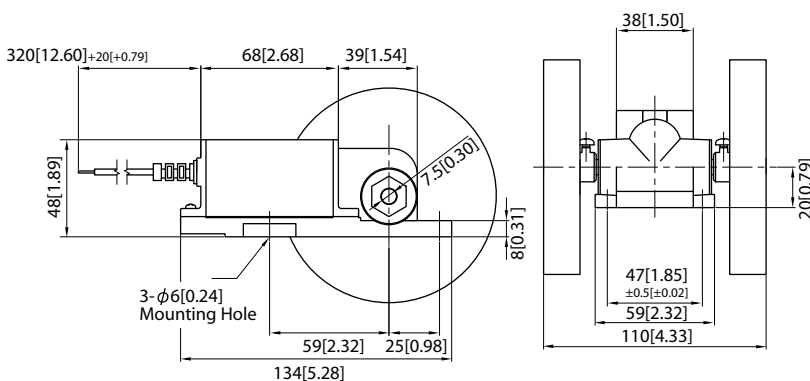

### WHEEL

	Meter Wheel	Yard Wheel
UNIT OF MEASURE	Meters	Yard
MODEL	MRM096	MRM097
TYPE OF SURFACE	Plain	
MATERIAL OF SURFACE	Thermoplastic Elastomer	

